

# RYWB117

**2.4GHz Ultra Low Power Wi-Fi / Bluetooth 5.0 Classic BR EDR 2.1  
UART/SPI Interface Module**

**Datasheet**

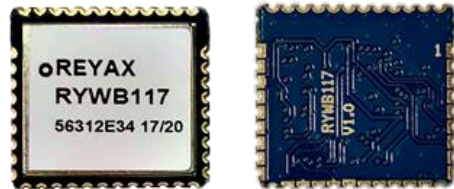

## PRODUCT DESCRIPTION

REYAX's RYWB117 module provides a comprehensive multi-protocol wireless solution including 802.11 b/g/n, dual-mode Bluetooth 5.

## FEATURES

- Compliant to single-spatial stream IEEE 802.11 b/g/n, Bluetooth 5.
- Co-existence of multiple wireless protocols managed by an internal protocol arbitration manager.
- Ultra-low power consumption with multiple power modes to reduce the system energy consumption.
- Leading edge RF performance providing long range and higher throughputs.
- Transmit power up to +20dBm with integrated PA.
- Wi-Fi receive sensitivity as low as -98.5 dBm.
- Support for Client mode, Access Point mode (Up to 8 clients), Concurrent Client and Access Point mode, and Enterprise Security. Support for concurrent Wi-Fi, Bluetooth 5.
- Support for Bluetooth dual-mode.
- Bluetooth inbuilt stack support for L2CAP, RFCOMM, SDP, SPP, GAP
- 8.9 mA transmit current in BT 5 mode, 2 Mbps data rate
- BT receive sensitivity as low as -95 dBm.
- Operating temperature: -40°C to +85°C
- Transmission distance up to 200M.

## BLOCK DIAGRAM

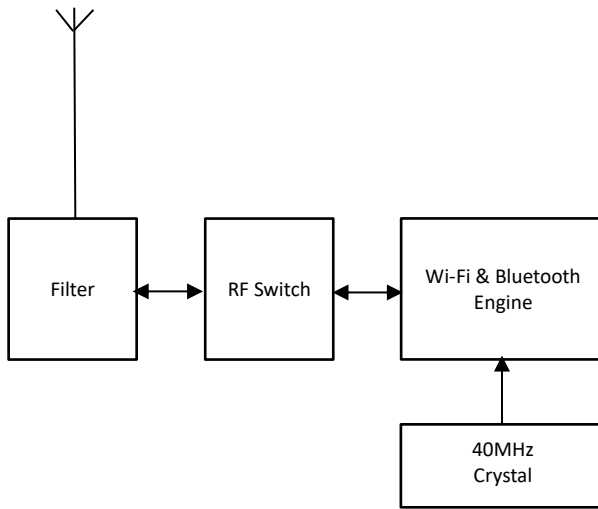

## PIN DESCRIPTION

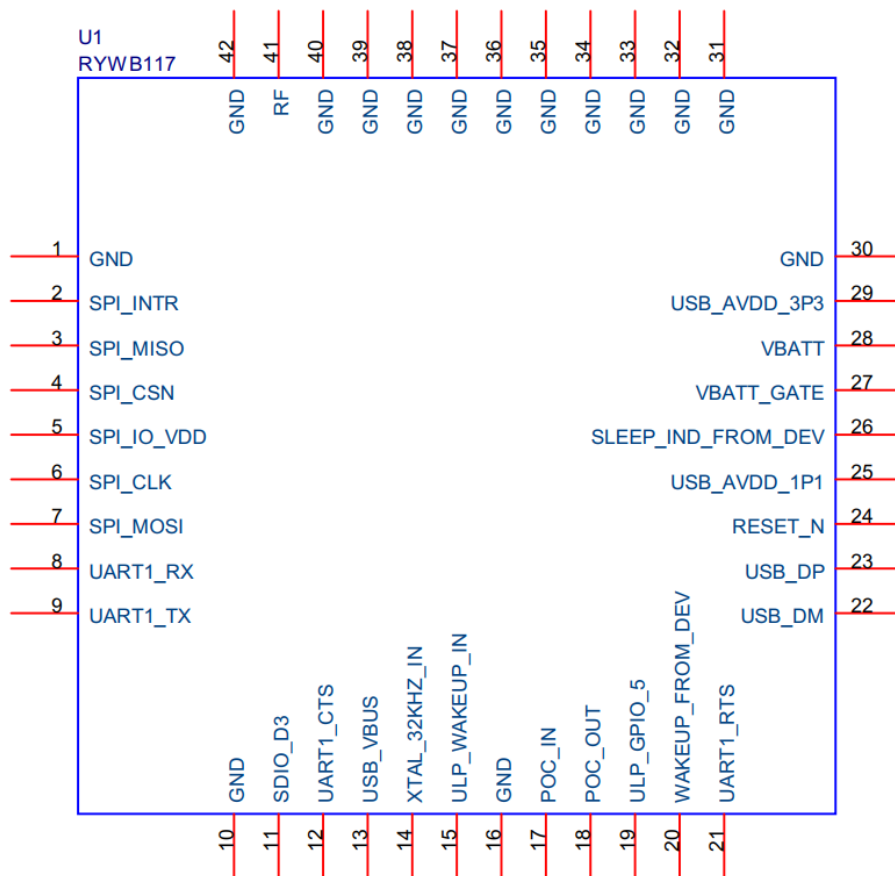

Pin	Name	I/O	Condition
1	GND	-	Ground
2	SPI_INTR	O	SPI_INTR: SPI Slave interface Interrupt Signal to the Host.
3	SPI_MISO	O	SPI_MISO: SPI Slave interface Master-In-Slave-Out signal.
4	SPI_CSN	I	SPI_CSN: Active-low Chip Select signal of SPI Slave interface.
5	SPI_IO_VDD	I	I/O Supply for GPIOs (1.9-3.6V).
6	SPI_CLK	I	SPI_CLK: SPI Slave interface clock.
7	SPI_MOSI	I	SPI Slave interface Master-Out-Slave-In signal.
8	UART1_RX	I	UART 1 interface serial input.
9	UART1_TX	O	UART 1 interface serial output.
10	GND	-	Ground
11	SDIO_D3	I/O	SDIO_D3: SDIO interface Data3 signal.
12	UART1_CTS	I	UART1_CTS: UART 1 interface Clear to Send.
13	USB_VBUS	I	Leave Unconnected.
14	XTAL_32KHZ_IN	I	This pin can be used to feed external clock from a host processor or from external crystal oscillator.
15	ULP_WAKEUP_IN	I	This signal has two functionalities – one during the bootloading process and one after the bootloading. During bootloading, this signal is an active-high input to indicate that the bootloader should bypass any inputs from the Host processor and continue to load the default firmware from Flash. After bootloading, this signal is an active-high input to indicate that the chip/module should wakeup from its Ultra Low Power (ULP) sleep mode.
16	GND	-	Ground
17	POC_IN	I	Power On Control Input.
18	POC_OUT	O	Power On Control Output.
19	ULP_GPIO_5	I	This is LP Powersave Wakeup indication to Device from HOST.
20	WAKEUP_FROM_DEV	O	Used as a wakeup indication to host from device.
21	UART1_RTS	O	UART1_RTS: UART 1 interface Request to Send.
22	USB_DM	I/O	Leave Unconnected
23	USB_DP	I/O	Leave Unconnected
24	RESET_N	I	Active-low reset asynchronous reset signal.
25	USB_AVDD_1P1	I	Power supply for the USB core.connect to GND.
26	SLEEP_IND_FROM_DEV	O	This signal is used to send an indication to the Host processor. An indication is sent when the chip enters (logic low) and exits (logic high) the ULP Sleep mode.
27	VBATT_GATE	I	If not use the power gate, please connect to the VBATT pin.

			The power gate reduces sleep mode current. Please refer to the EVB Schematic.
28	VBATT	I	Input supply voltage (1.75-3.6V).
29	USB_AVDD_3P3	I	Power Supply for the USB interface. connect to GND.
30	GND	-	Ground
31	GND	-	Ground
32	GND	-	Ground
33	GND	-	Ground
34	GND	-	Ground
35	GND	-	Ground
36	GND	-	Ground
37	GND	-	Ground
38	GND	-	Ground
39	GND	-	Ground
40	GND	-	Ground
41	RF	I/O	RF Signal Input/Output
42	GND	-	Ground

# EVB APPLICATION SCHEMATIC

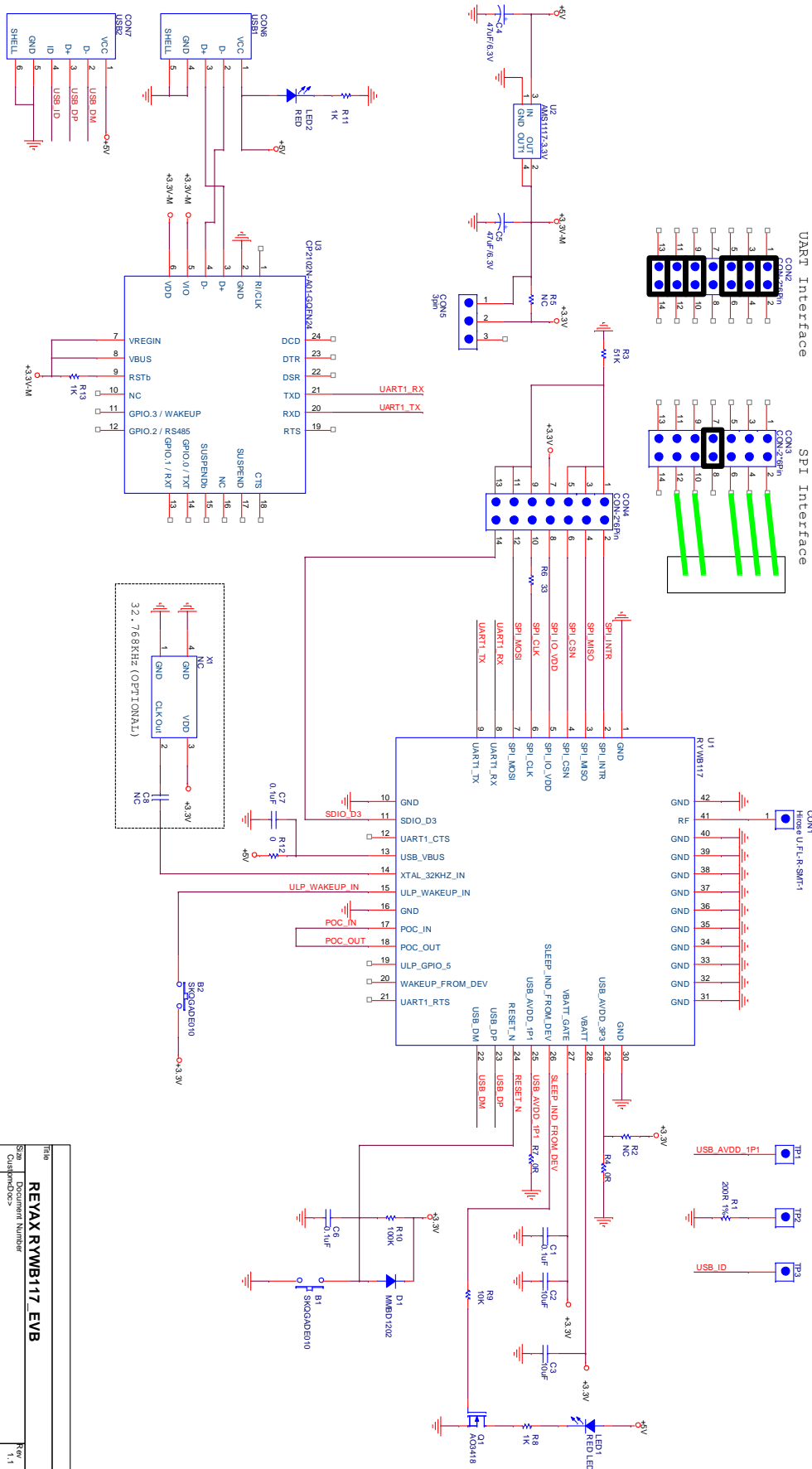

Title	REYAX RYWB117 EVB
Part Number	RYWB117
Rev	1
Date	Thursday, November 25, 2021
Sheet	1 of 1

## SPECIFICATION

Item	Min.	Typical	Max.	Unit	Description
Operation Voltage	1.75	3.3	3.6	V	VBATT
I <sub>max</sub>			400	mA	Maximum Current consumption in TX mode
I <sub>Pmax</sub>			500	mA	Peak current rating for power supply
WLAN Data Transfer Average Current		270		mA	11Mbps Tx
WLAN Data Receive Average Current		48.2		mA	72 Mbps Rx
BR/EDR TX Active Current, 3 Mbps EDR		140		mA	HP chain, Tx Power = Maximum
BR/EDR RX Active Current, 3 Mbps EDR		26.7		mA	HP chain
BLE TX Active Current		190		mA	HP Chain, Tx Power = Maximum (20 dBm)
BLE RX Active Current		26.7		mA	HP chain
WLAN Standby Associated Mode Current		119		uA	DTIM=3 Cisco Aironet AP
WLAN Standby Associated Mode Current		51		uA	DTIM=10 Cisco Aironet AP
Quiescent current		3		nA	
Baud Rate	9600	115200	921600	bps	
Wireless Protocols					IEEE 802.11b, 802.11g, 802.11n Bluetooth 5 (2.1+EDR, LE, LE 2 Mbp)
Operational Modes Supported					Wi-Fi Access Point with support for up to 16 clients Wi-Fi Client Bluetooth Classic (EDR v 2.1) Wi-Fi Client + Bluetooth Low Energy
Receive Power			10	dBm	
WLAN Modulation					OFDM with BPSK, QPSK, 16-QAM, and 64-QAM 802.11b with CCK and DSSS
WLAN Operating Frequency	2.412		2.484	GHz	
WLAN Bandwidth		20		MHz	
WLAN Data Rates	1 6		11 54	Mbps	802.11b: 1, 2, 5.5, 11Mbps 802.11g: 6, 9, 12, 18, 24, 36, 48, 54Mbps 802.11n: MCS0 to MCS7
Bluetooth Channel Spacing	1		2	MHz	BR, EDR, - 1 MHz LE - 2 MHz

Bluetooth Modulation		GFSK, DQPSK, D8PSK			
Bluetooth Operating Frequency	2.402		2.480	GHz	
Bluetooth Data Rates	125		3000	Kbps	
Communication Range			266	M	
Weight		0.71		g	
Operating Temperature	-40	25	+85	°C	

## DC CHARACTERISTICS

### RESET\_N PIN

Symbol	Min.	Typical	Max.	Unit	Parameter
V <sub>IH</sub>	0.8 VDD		3.63	V	High level input voltage
V <sub>IL</sub>	-0.5		0.3 VDD	V	Low-level input voltage
V <sub>hys</sub>	0.05 VDD			V	Hysteresis voltage

### DIGITAL INPUT OUTPUT SIGNALS

Symbol	Min.	Typical	Max.	Unit	Parameter
V <sub>IH</sub>	2.0		3.63	V	High level input voltage
V <sub>IL</sub>	-0.3		0.8	V	Low-level input voltage
V <sub>hys</sub>	0.1 VDD			V	Hysteresis voltage
V <sub>OL</sub>			0.4	V	Low level output voltage
V <sub>OH</sub>	VDD-0.4			V	High level output voltage
I <sub>OL</sub>	2.0	4.0	12.0	mA	Low level output current
I <sub>OH</sub>	2.0	4.0	12.0	mA	High level output current

### PIN CAPACITANCE

Symbol	Parameter	Min.	Typical	Max.	Unit
C <sub>io</sub>	Input/output capacitance, digital pins only			2.0	pF



## WIRELESS PERFORMANCE SPECIFICATIONS

### WLAN 2.4 GHz TRANSMITTER CHARACTERISTICS

Parameter	Conditions	Min.	Typical	Max.	Unit
Transmit Power for 20MHz Bandwidth, compliant with IEEE mask and EVM	1 Mbps DSSS		20		dBm
	2 Mbps DSSS		20		dBm
	5.5 Mbps CCK		20		dBm
	11 Mbps CCK		20		dBm
	6 Mbps OFDM		20		dBm
	9 Mbps OFDM		20		dBm
	12 Mbps OFDM		20		dBm
	18 Mbps OFDM		20		dBm
	24 Mbps OFDM		19		dBm
	36 Mbps OFDM		18		dBm
	48 Mbps OFDM		18		dBm
	54 Mbps OFDM		17		dBm
	MCS0 Mixed Mode		20		dBm
	MCS1 Mixed Mode		20		dBm
	MCS2 Mixed Mode		20		dBm
	MCS3 Mixed Mode		19		dBm
	MCS4 Mixed Mode		17.5		dBm
MCS5 Mixed Mode		17.5		dBm	
MCS6 Mixed Mode		17		dBm	
MCS7 Mixed Mode		14		dBm	

### WLAN 2.4 GHz RECEIVER CHARACTERISTICS

Parameter	Conditions	Min.	Typical	Max.	Unit
Sensitivity for 20MHz Bandwidth	1 Mbps DSSS		-98.5		dBm
	2 Mbps DSSS		-93		dBm
	5.5 Mbps CCK		-90		dBm
	11 Mbps CCK		-88		dBm
	6 Mbps OFDM		-93		dBm
	9 Mbps OFDM		-92		dBm

	12 Mbps OFDM		-91		dBm
	18 Mbps OFDM		-89		dBm
	24 Mbps OFDM		-85.5		dBm
	36 Mbps OFDM		-82.5		dBm
	48 Mbps OFDM		-78		dBm
	54 Mbps OFDM		-76.5		dBm
	MCS0 Mixed Mode		-91.5		dBm
	MCS1 Mixed Mode		-90		dBm
	MCS2 Mixed Mode		-88		dBm
	MCS3 Mixed Mode		-85		dBm
	MCS4 Mixed Mode		-81		dBm
	MCS5 Mixed Mode		-77		dBm
	MCS6 Mixed Mode		-75		dBm
	MCS7 Mixed Mode		-73		dBm
Maximum Input Level for PER below 10%	1 Mbps DSSS		0		dBm
	11 Mbps CCK		-10		dBm
	54 Mbps OFDM		-10		dBm
	MCS0 Mixed Mode		-10		dBm
Adjacent Channel Rejection	1 Mbps DSSS		36		dB
	11 Mbps CCK		37		dB
	6 Mbps OFDM		38		dB
	54 Mbps OFDM		22		dB
Return Loss		-10			dB
RSSI Accuracy		-3		+3	dB

## BLUETOOTH TRANSMITTER CHARACTERISTICS

Parameter	Conditions	Min.	Typical	Max.	Unit
Transmit Power	BR, EDR		20		dBm
	LE		-1		dBm
Power Control Step	BR, EDR		3		dB
Adjacent Channel Power  M-N  = 2	BR		-20		dB
	EDR		-20		dB
	LE		-20		dB
Adjacent Channel Power  M-N  > 2	BR		-40		dB
	EDR		-40		dB
	LE		-30		dB

## BLUETOOTH RECEIVER CHARACTERISTICS

Parameter	Conditions	Min.	Typical	Max.	Unit
Sensitivity	BR (1 Mbps), 339 bytes, DH5 Packet		-93.5		dBm
	EDR2 (2 Mbps), 679 bytes, 2-DH5 Packet		-94		dBm
	EDR3 (3 Mbps), 1020 bytes, 3-DH5 Packet		-88		dBm
	LE (1 Mbps), 37 bytes, Advertising Channel		-95		dBm
Maximum Input Level	BR, EDR2, EDR3		-16		dBm
	LE		-8		dBm
BER Floor				1e-4	%
C/I Performance	BR, co-channel		9		dB
	BR, adjacent +1 MHz		-2		dB
	BR, adjacent -1 MHz		-2		dB
	BR, adjacent +2 MHz		-19		dB
	BR, adjacent $\geq  \pm 3 $ MHz		-19		dB
	BR, adjacent to image channel		-22		dB
	EDR2, co-channel		11		dB
	EDR2, adjacent +1 MHz		-2		dB
	EDR2, adjacent -1 MHz		-2		dB
	EDR2, adjacent +2 MHz		-17		dB
	EDR2, adjacent -2 MHz		-17		dB
	EDR2, adjacent $\geq  \pm 3 $ MHz		-17		dB
	EDR3, co-channel		19		dB
	EDR3, adjacent +1 MHz		3		dB
	EDR3, adjacent -1 MHz		3		dB
	EDR3, adjacent +2 MHz		-12		dB
	EDR3, adjacent -2 MHz		-12		dB
	EDR3, adjacent $\geq  \pm 3 $ MHz		-12		dB
	LE, co-channel		19		dB
	LE, adjacent +1 MHz		13		dB
LE, adjacent -1 MHz		13		dB	
LE, adjacent +2 MHz		-19		dB	
LE, adjacent -2 MHz		-19		dB	
LE, adjacent $\geq  \pm 3 $ MHz		-19		dB	

## REFLOW SOLDERING

Consider the "IPC-7530 Guidelines for temperature profiling for mass soldering (reflow and wave) processes, published 2001.

### Preheat phase

Initial heating of component leads and balls. Residual humidity will be dried out. Please note that this preheat phase will not replace prior baking procedures.

- Temperature rise rate: max. 3 °C/s If the temperature rise is too rapid in the preheat phase it may cause excessive slumping.
- Time: 60 - 120 s If the preheat is insufficient, rather large solder balls tend to be generated. Conversely, if performed excessively, fine balls and large balls will be generated in clusters.
- End Temperature: 150 - 200 °C If the temperature is too low, non-melting tends to be caused in areas containing large heat capacity.

### Heating/ Reflow phase

The temperature rises above the liquidus temperature of 217°C. Avoid a sudden rise in temperature as the slump of the paste could become worse.

- Limit time above 217 °C liquidus temperature: 40 - 60 s
- Peak reflow temperature: 245 °C

### Cooling phase

A controlled cooling avoids negative metallurgical effects (solder becomes more brittle) of the solder and possible mechanical tensions in the products. Controlled cooling helps to achieve bright solder fillets with a good shape and low contact angle.

- Temperature fall rate: max 4 °C/s To avoid falling off, the REYAX RYWB117 module should be placed on the topside of the motherboard during soldering.

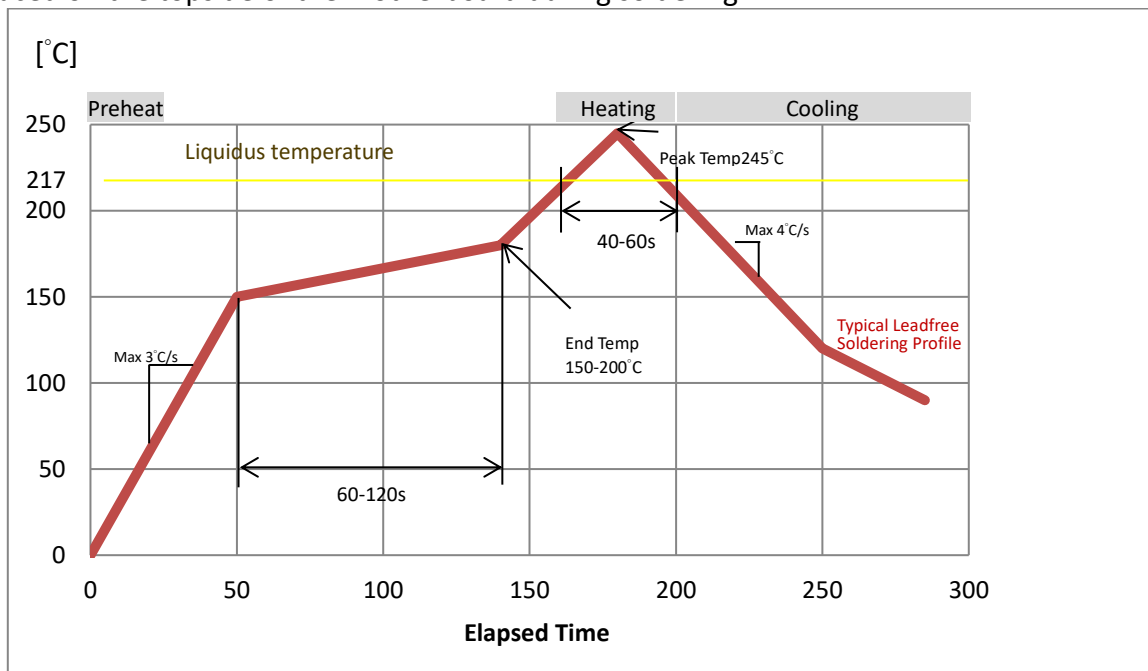

### Recommended soldering profile

\*Note: Does not support upside-down/bottom side reflow.

## DIMENSIONS

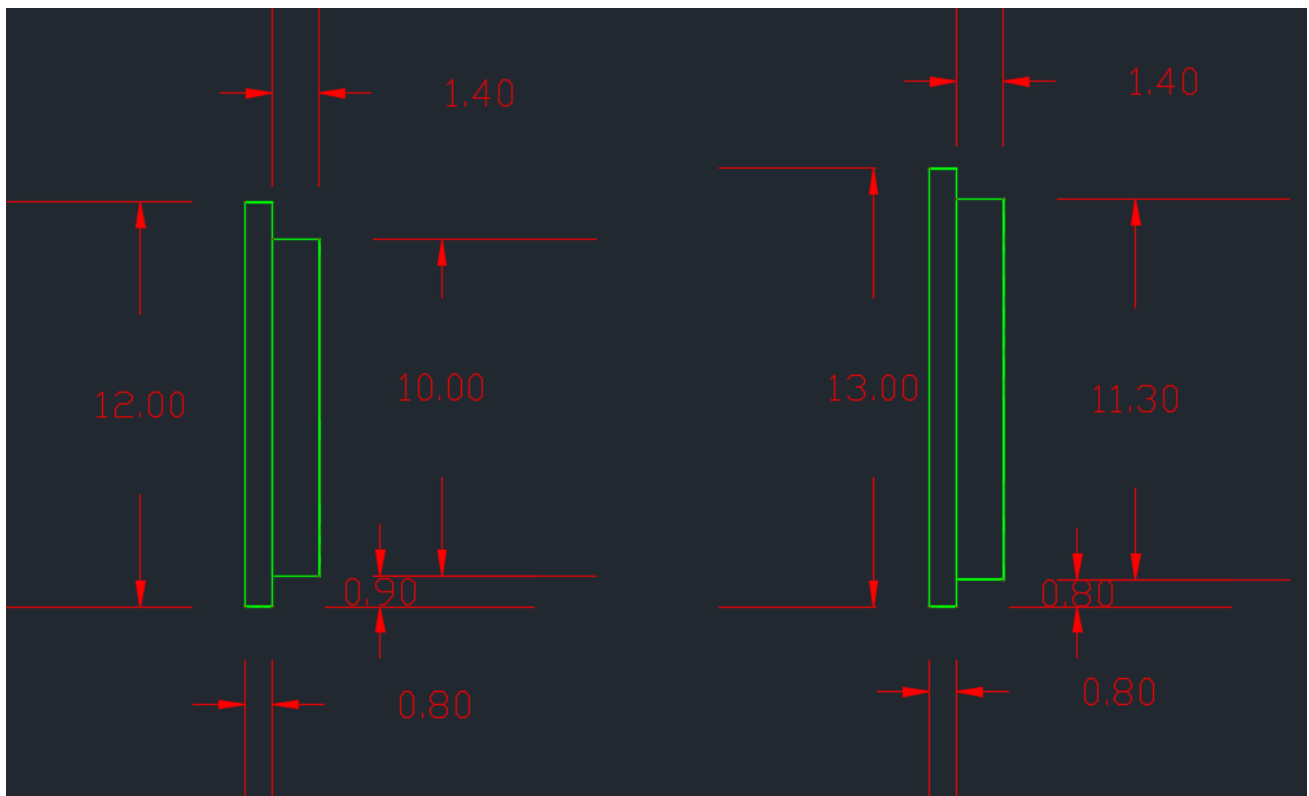
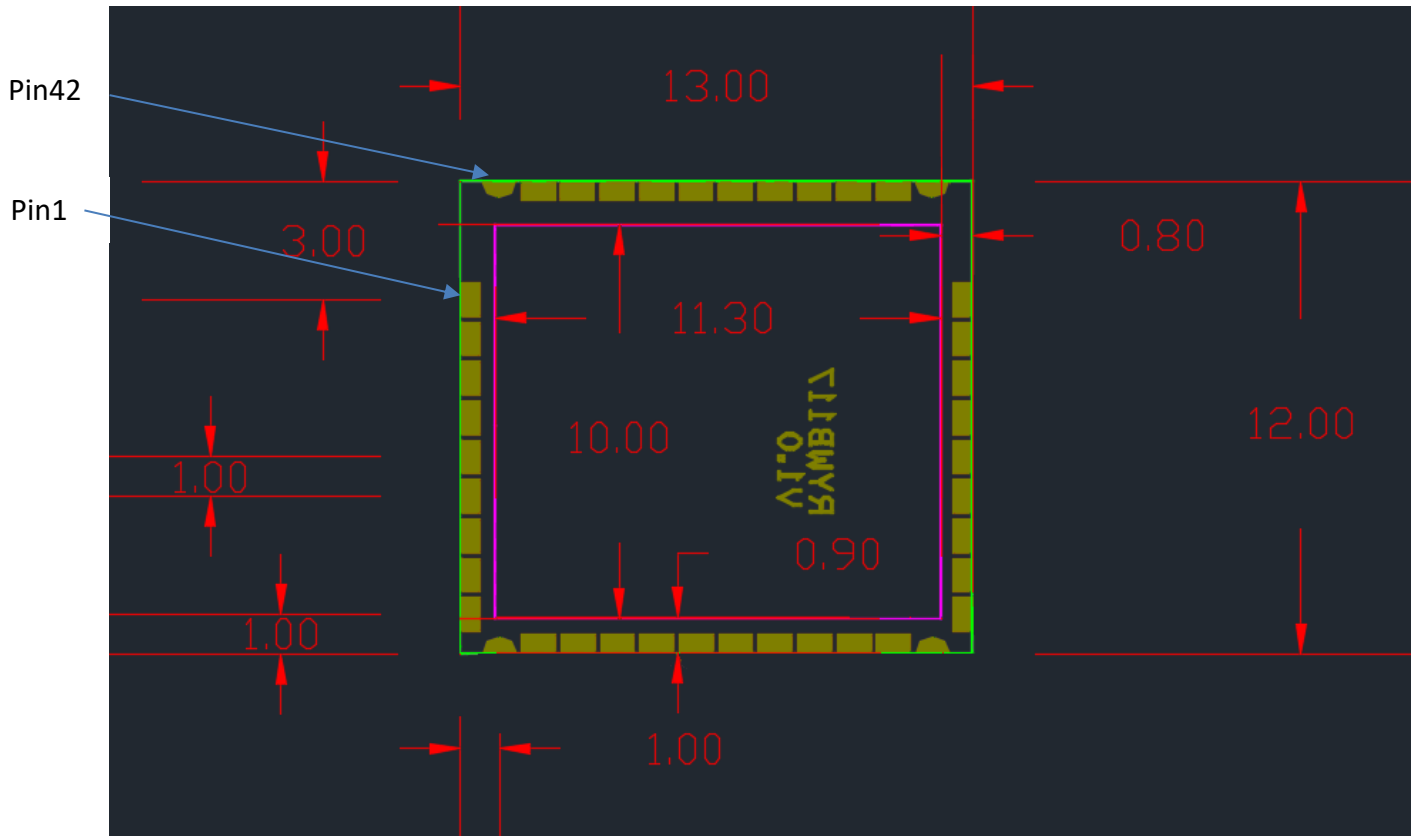

unit : mm

## LAYOUT FOOTPRINT RECOMMENDATIONS

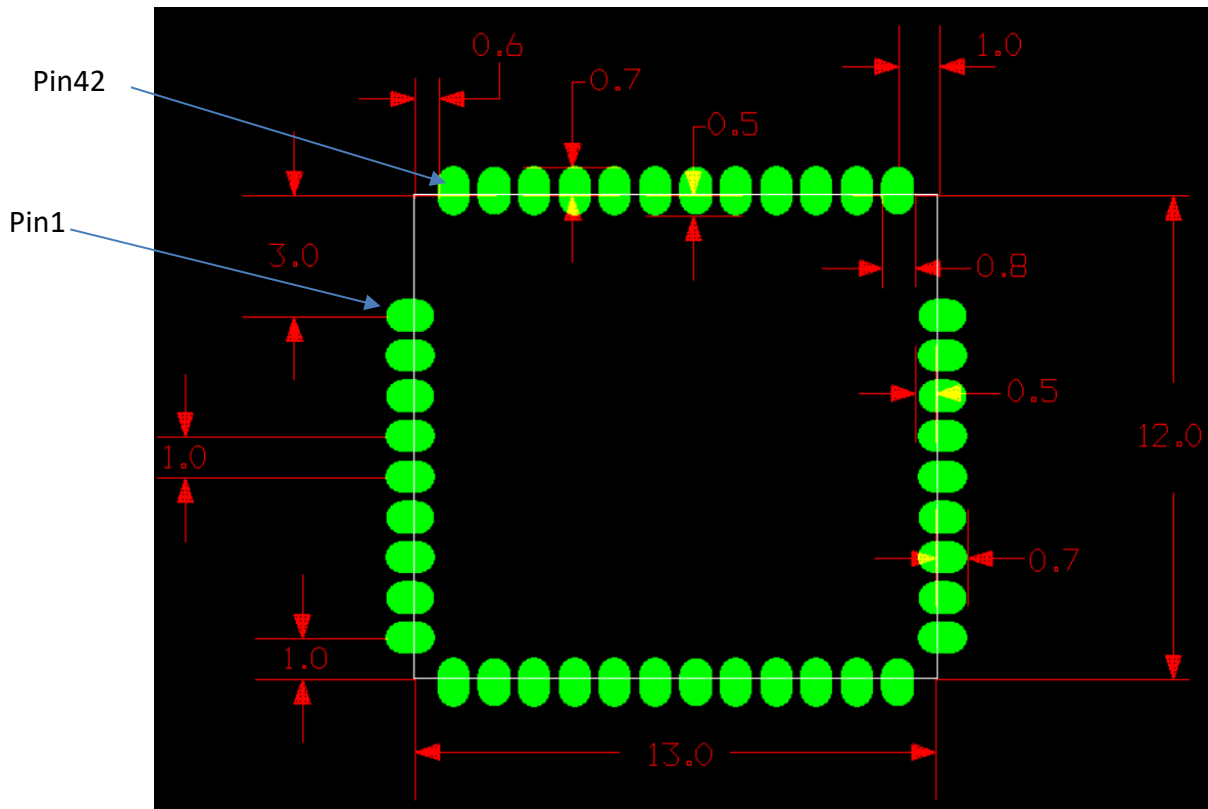

unit : mm