

# RYLR998

UART Interface  
868/915 MHz LoRa®  
Antenna Transceiver Module

Datasheet



## PRODUCT DESCRIPTION

The RYLR998 transceiver module feature the LoRa® long range modem that provides ultra-long range spread spectrum communication and high interference immunity whilst minimizing current consumption.

## FEATURES

- NUVOTON MCU & Semtech LoRa® Engine
- Excellent blocking immunity
- Smart receiving power saving mode
- High sensitivity
- Control easily by AT commands
- Built-in antenna
- Command support data encryption

## APPLICTIONS

- IoT Applications
- Mobile Equipment
- Home Security
- Industrial Monitoring and Control Equipment

## CERTIFICATION

- FCC
- CE RED
- NCC

## PIN DESCRIPTION

RYLR998

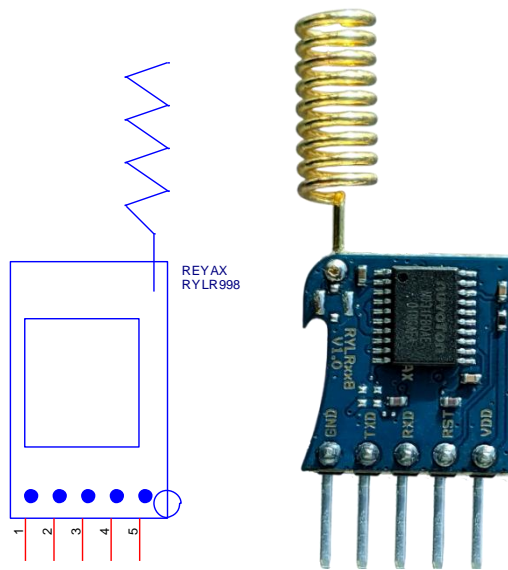

RYLR998\_M4

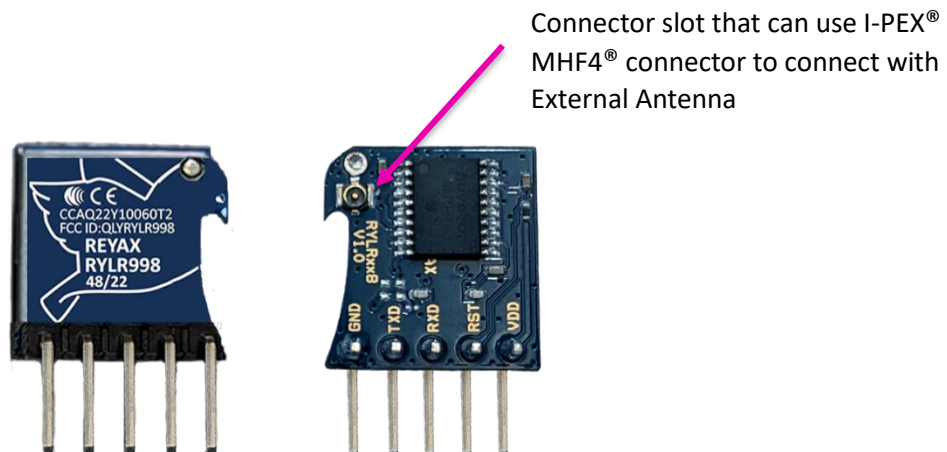

Pin	Name	I/O	Condition
1	VDD	I	Power Supply
2	NRST	I	RESET(Active Low) 100KΩ Internal pull up, Pull down at least 100ms
3	RXD	I	UART Data Input
4	TXD	O	UART Data Output
5	GND	-	Ground

## TIMING DIAGRAM

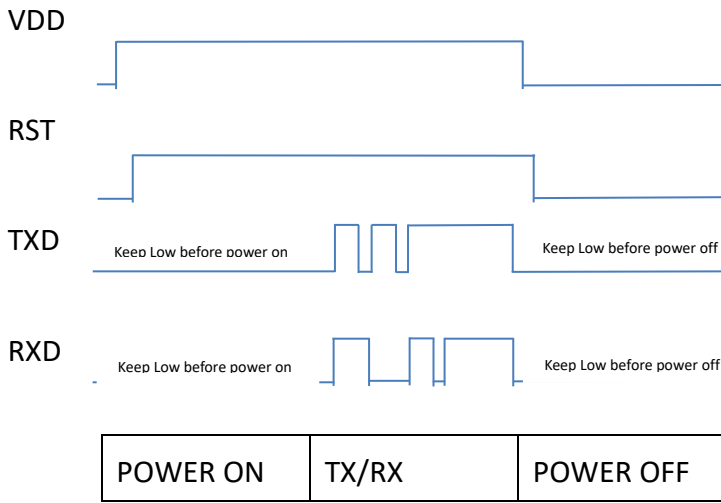

## BLOCK DIAGRAM

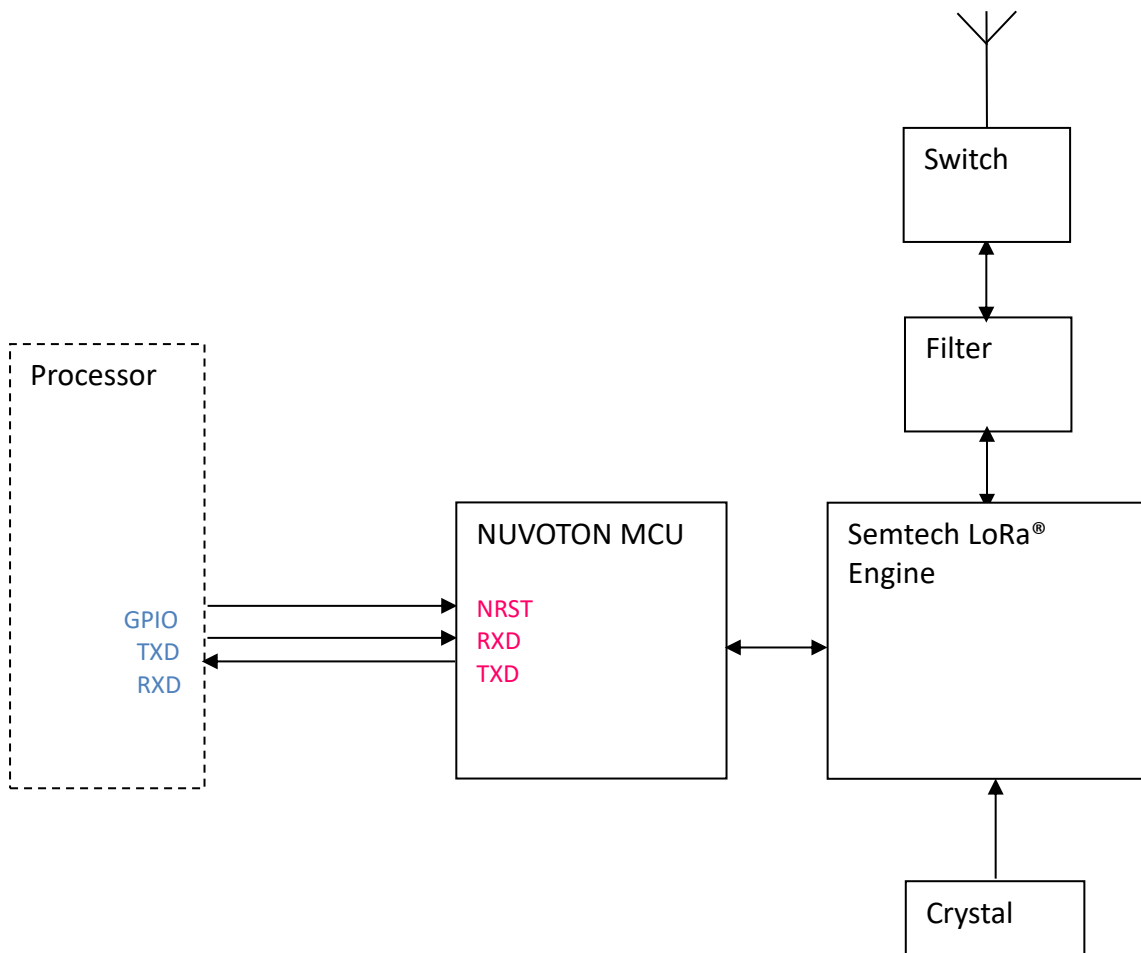

## SPECIFICATION

Item	Min.	Typical	Max.	Unit	Condition
VDD Power supply	2.3	3.3	3.6	V	VDD
RF Output power range	0		22	dBm	RF Output Power must be set to less than AT+CRFOP=14 to comply with CE certification.
Filter insertion loss	1	2	3	dB	
RF Sensitivity	-129			dBm	
RF Input level			10	dBm	
Frequency range	820	868/915	960	MHz	
Frequency accuracy		±10		ppm	
Transmit Mode current		140		mA	RFOP = +22dBm
Receive Mode current		17.5		mA	@VDD=+3.3V
Sleep mode current		10		uA	AT+MODE=1 @VDD=+3.3V
Smart receiving power saving mode average current	0.06	2.65	5.5	mA	2.65mA @AT+MODE=2,1000,1000 If you need lower current consumption, you can adjust the AT+MODE=2 time duty.
Baud rate	300	115200	115200	bps	8, N, 1
Digital Input Level High	0.7*VDD		VDD	V	VIH
Digital Input Level Low	0		0.3*VDD	V	VIL
Digital Output Level High	0.9		VDD	V	VOH
Digital Output Level Low			0.1	V	VOL
Cycling (erase / write) Flash data memory		200		K	Cycles
Weight		1.83		g	
Operating temperature	-40	25	+85	°C	

## TRANSMIT POWER CONSUMPTION TEST

AT+CRFOP (dBm)	Typical Current (mA) VDD=3.3V	
0	56.6	
1	59.4	
2	63.3	
3	65.7	
4	70.3	
5	73.2	
6	77.0	
7	81.2	
8	85.4	
9	90.0	
10	94.4	
11	99.3	
12	104.6	
13	110.6	
14	115.5	
15	119.4	
16	122.5	
17	125.5	
18	129.2	
19	133.4	
20	138.1	
21	141.6	
22	144.7	

## SMART RECEIVING POWER SAVING MODE

When UART RXD interface receives AT+MODE=2,<RX time>,<Low speed time> command, RF Reception will enter the <RX time>/<Low speed time> according to the parameters, When RF Transmission is at <RX time> the data will be decoded. Then the data will be output on UART TXD interface, The RYLRx98 will return to +MODE=0 at same time.

If you want to enter “Smart receiving power saving mode” again, you need to execute AT+MODE=2,<RX time>,<Low speed time> command.

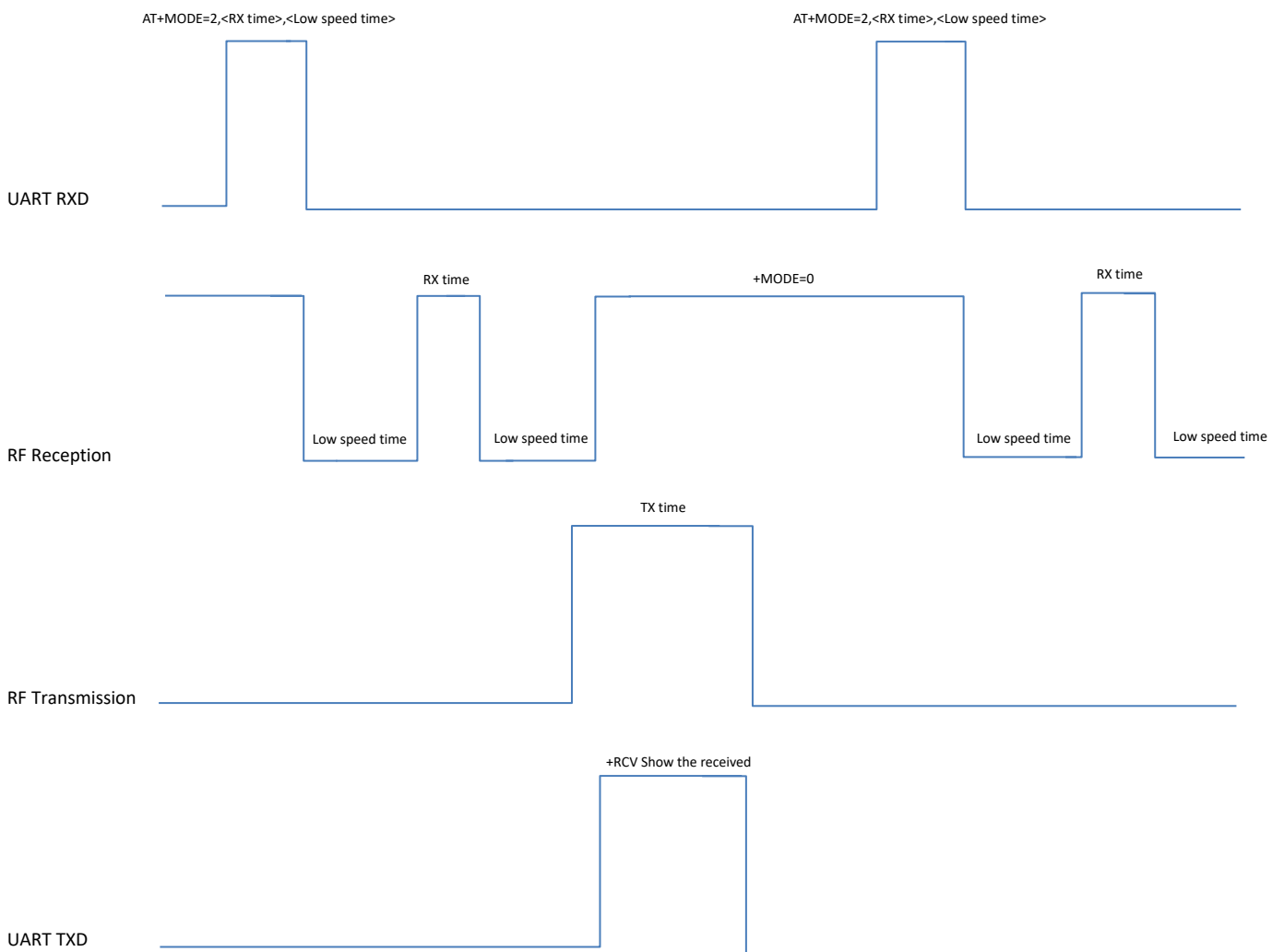

## SMART RECEIVING POWER SAVING MODE CURRENT TEST

Time duty	Average current(mA)	Parameter
AT+MODE=2,30,60000	0.057	AT+PARAMETER=5,7,1,12 only
AT+MODE=2,100,60000	0.061	Any
AT+MODE=2,100,50000	0.063	Any
AT+MODE=2,100,40000	0.065	Any
AT+MODE=2,100,30000	0.067	Any
AT+MODE=2,100,20000	0.069	Any
AT+MODE=2,100,10000	0.071	Any
AT+MODE=2,100,1000	0.525	Any
AT+MODE=2,1000,1000	2.65	Any



## DATA LATENCY TIME TEST

Measure the time difference between the UART RXD receiving the AT+SEND command and the UART TXD outputting +RCV data.

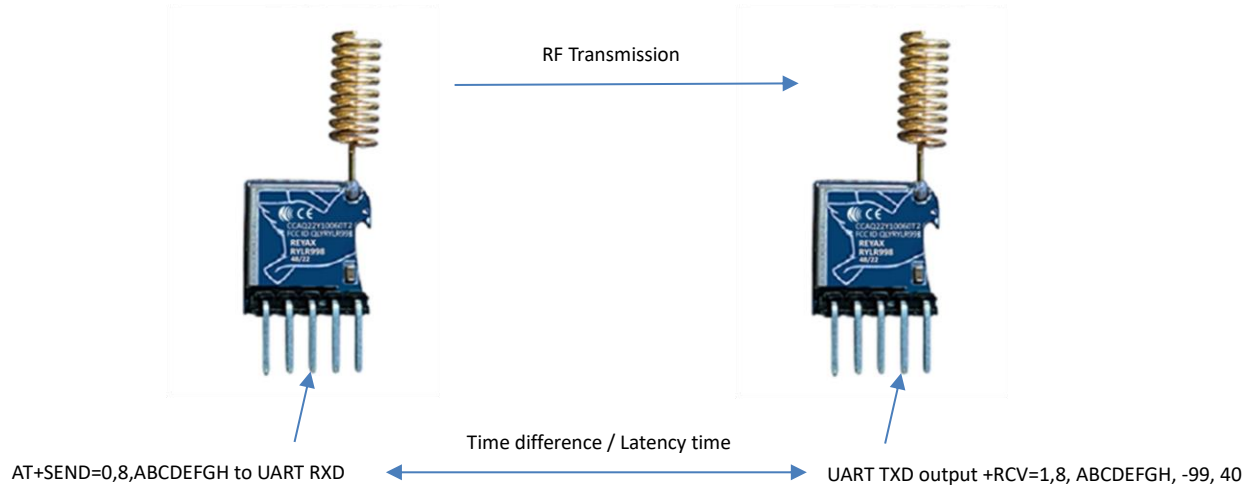

Parameter	Latency time(mSec)
AT+PARAMETER=5,9,1,4	9.52
AT+PARAMETER=5,8,1,12	13.62
AT+PARAMETER=9,8,1,12	98.85
AT+PARAMETER=9,7,1,12	190.7
AT+PARAMETER=11,9,1,24	220.2

## DIMENSIONS

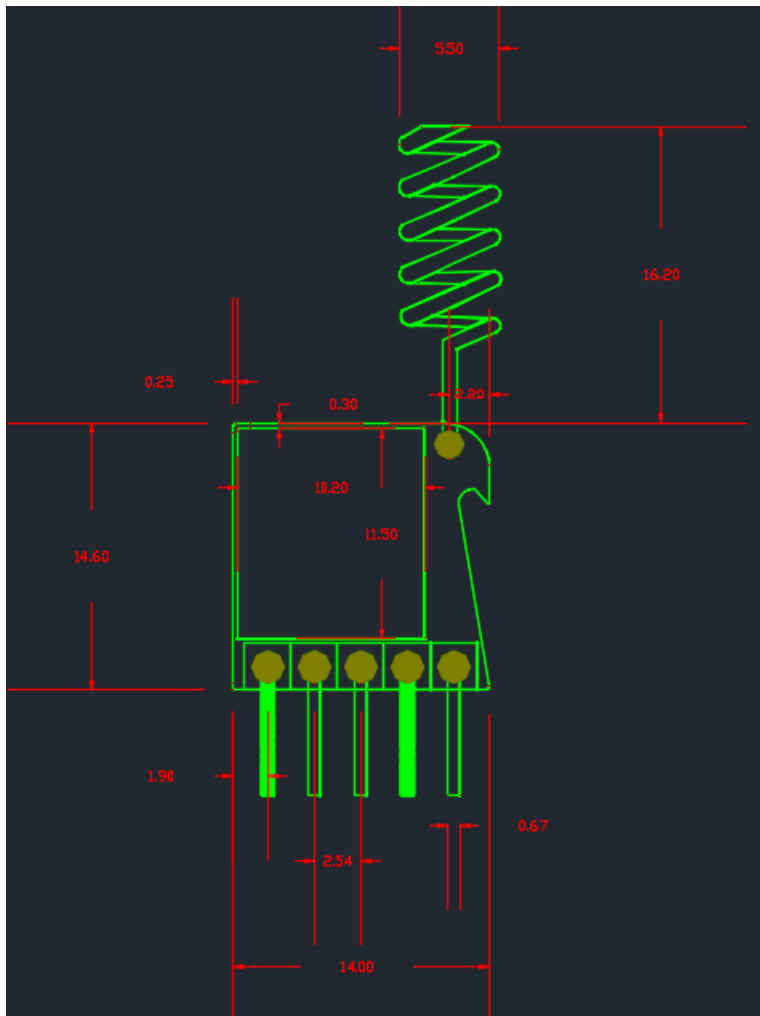

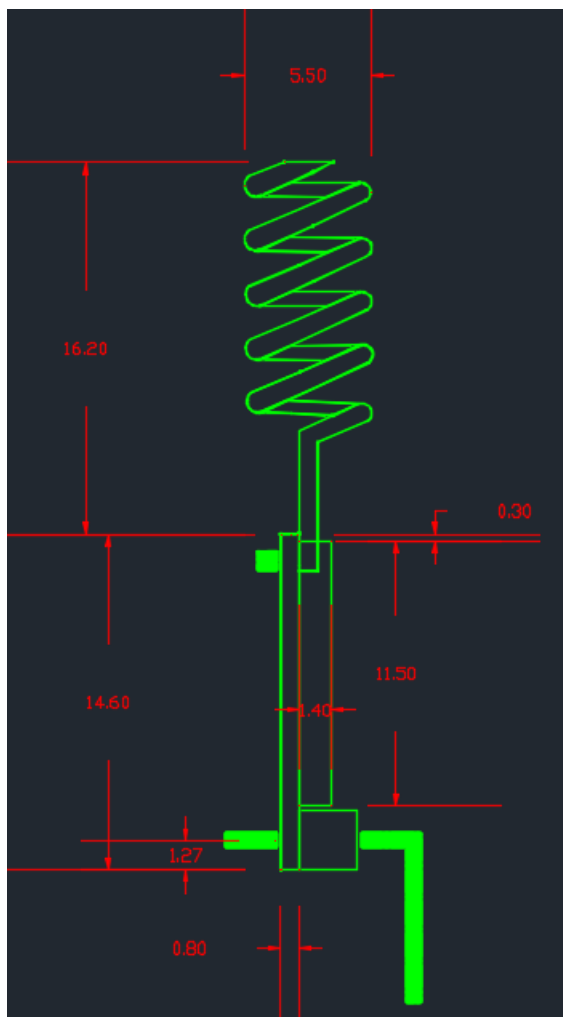

Unit : mm

**\*For more detail, please refer to the 3D model Information.**

## TRAY

Every 100pcs RYLR998 will be placed in a tray. Another tray will be placed above each tray.

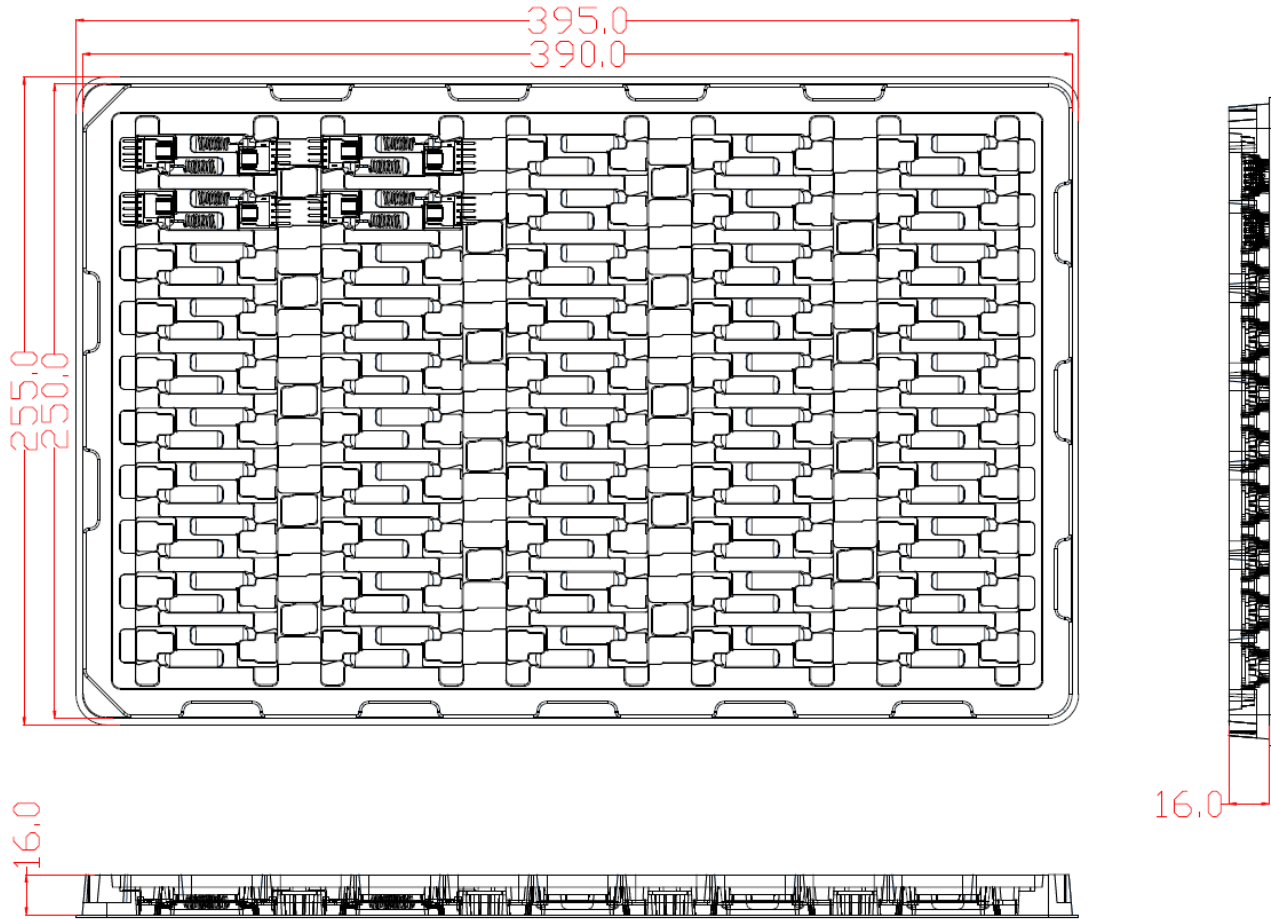

Unit : mm

## CERTIFICATION INFORMATION

### Taiwan NCC Statement 低功率電波輻射性電機管理辦法:

第十二條 經型式認證合格之低功率射頻電機，非經許可，公司、商號或使用者均不得擅自變更頻率、加大功率或變更原設計之特性及功能。

第十四條 低功率射頻電機之使用不得影響飛航安全及干擾合法通信；經發現有干擾現象時，應立即停用，並改善至無干擾時方得繼續使用。前項合法通信，指依電信法規定作業之無線電通信。低功率射頻電機須忍受合法通信或工業、科學及醫療用電波輻射性電機設備之干擾。



**CCAQ22Y10060T2**

### FCC Statement:

This device complies with part 15 of the FCC Rules. Operation is subject to the following two conditions:

- (1) This device may not cause harmful interference, and
- (2) this device must accept any interference received, including interference that may cause undesired operation.

NOTE: This equipment has been tested and found to comply with the limits for a Class B digital device, pursuant to part 15 of the FCC Rules. These limits are designed to provide reasonable protection against harmful interference in a residential installation. This equipment generates, uses and can radiate radio frequency energy and, if not installed and used in accordance with the instructions, may cause harmful interference to radio communications. However, there is no guarantee that interference will not occur in a particular installation.

If this equipment does cause harmful interference to radio or television reception, which can be determined by turning the equipment off and on, the user is encouraged to try to correct the interference by one or more of the following measures:

- Reorient or relocate the receiving antenna.
- Increase the separation between the equipment and receiver.
- Connect the equipment into an outlet on a circuit different from that to which the receiver is connected.
- Consult the dealer or an experienced radio/TV technician for help.

Changes or modifications not expressly approved by the party responsible for compliance could void the user's authority to operate the equipment.

### LABEL OF THE END PRODUCT:

The final end product must be labeled in a visible area with the following " Contains TX FCC ID : QLYRYLR998 ". If the size of the end product is larger than 8x10cm, then the following FCC part 15.19 statement has to also be available on the label: This device complies with Part 15 of FCC rules. Operation is subject to the following two conditions: (1) this device may not cause harmful interference and (2) this device must accept any interference received, including interference that may cause undesired operation.



ETSI EN 300 220-1 V3.1.1 (2017-02)  
ETSI EN 300 220-2 V3.2.1 (2018-06)

## ORDER INFORMATION

Ordering No.	Pin Header	Antenna or I-PEX® MHF4® Connector
RYLR998	90 Degree Angle	Antenna
RYLR998_M4	90 Degree Angle	I-PEX® MHF4® Connector
RYLR998_NP	Not mount	Antenna
RYLR998_M4_NP	Not mount	I-PEX® MHF4® Connector